



COMMUNITY DEVELOPMENT DIVISION

Building Inspections Department

GOVERNMENT CENTER · 200 FOURTH AVENUE WEST · SHAKOPEE, MN 55379-1220
(952) 496-8475 · Fax (952) 496-8496 · Web <http://www.co.scott.mn.us>

RE-ROOFING

General Information:

- Complete a building permit application (available at the Scott County Community Development Office).
- Permits should be applied for by the contractor doing the work.

Fees:

- Permit fees are a flat fee of **\$80.50** for all residential re-roofs.

Required Inspections:

- Two inspections are required – the first, after roofing tear off and the second when completed.
- If roof deck needs repair, an inspection shall be made during tear-off.
- If roof deck needs no repairs, the inspection will be during underlayment and ice/water shield installation.
- If not possible to inspect during roofing work, the applicant shall provide documentation such as pictures depicting the sheathing, underlayment and ice/water shield prior to a final inspection.

Any questions, please call Scott County Community Development at 952-496-8475.



Asphalt Roofing Shingles Information Sheet

Existing residential roofs

According to the 2006 International Residential Code the state of Minnesota has been classified a moderate exposure for hail damage. As such, the code dictates that no overlay of asphalt shingles is allowed. All re-roofing projects will require the existing roof system be removed.

Fasteners

Asphalt shingles shall be fastened with not less than four nails. Nails shall be not less than 12-gauge with 3/8 inch minimum diameter heads. Nails shall be of sufficient length to penetrate through roofing material and at least 3/4 inch into roof sheathing or through the thickness of the sheathing, whichever is less. Nail head shall be driven so that it tightly bears against the shingle but does not cut the surface of the shingle. Nails must be installed in the location on each shingle per the manufacturer's instructions. **Any crooked nails should be removed and replaced.** (See illustration.)

Note: Use of other types of fasteners must be approved by the Building and Inspection Division.

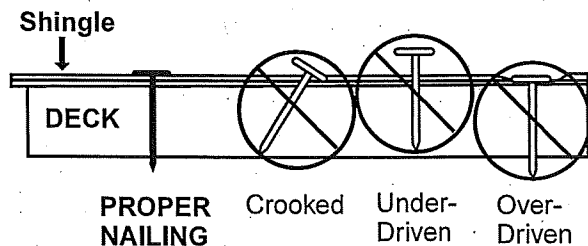

Sheathing

Roof sheathing shall be checked prior to re-roofing and repaired or replaced if rotted or unsound. Replacement sheathing shall conform to the requirements of the Building Code and the manufacturer of the product.

Roof pitch

Asphalt shingles **shall not** be used on roofs with less than a 2:12 pitch and require special application procedures for pitches less than 4:12. Manufacturer's instructions on package must be followed.

Underlayment

A. For roof pitches of 2:12 to less than 4:12

Two layers of 15# felt applied shingle fashion. Starting with a 19 inch strip and a 36 inch wide sheet over it at the eaves, each subsequent sheet shall be lapped 19 inches horizontally.

Note: For ice protection materials, the manufacturer's installation instructions must be followed.

B. For roof pitches of 4:12 and over

One layer of 15# felt lapped two inches horizontally and 4 inches vertically. End laps shall be offset by six feet in all applications.

Valley underlayment

Valley linings shall be installed per the manufacturer's requirements before applying shingles.

Ice dam protection membranes

Required for all building structures. An exception is provided for **detached**, accessory structures that contain no conditioned floor area.

A. For roof pitches of 2:12 to less than 4:12

Same as for underlayment and, additionally, an approved waterproofing underlayment shall be installed to a point no less than 24 inches inside the interior wall line. When the manufacturer's specifications are more restrictive than the Building Code, the manufacturer's specifications shall be followed.

B. For roof pitches of 4:12 and over

Same as for underlayment and, additionally, a manufactured ice protection membrane or its code-approved equivalent assembly must be installed per manufacturer's instructions including, but not limited to, the following: The membrane shall extend from over the metal or wood drip edge to a point not less than 24 inches measured horizontally inside the exterior wall line. Depending on the depth of the soffit and width of the product, more than one layer could be required. The underlayments **must** extend to the outer edge at all fascia boards.

Vertical wall flashing (26-gauge)

1. Apply shingles up the roof until a course must be trimmed to fit at the base of the vertical wall. Plan to adjust the exposure slightly (and evenly) in the previous courses, so that the last shingle is at least 8 inches wide (vertically). This allows a minimum 5 inch exposure of the top course and a 3 inch headlap.

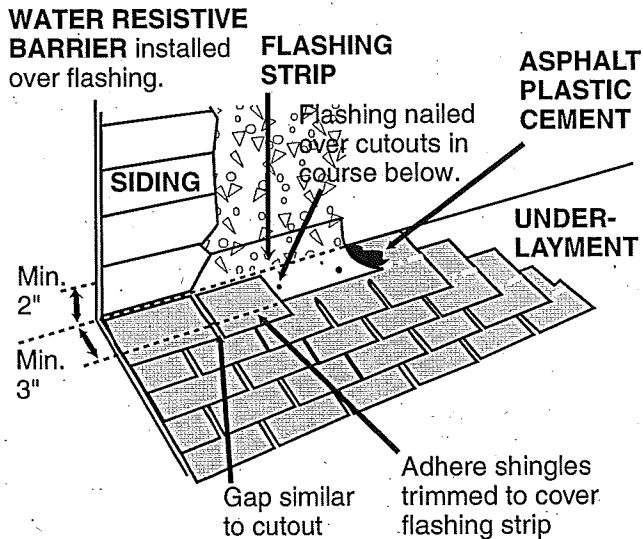

2. The flashing strip should be bent, using a metal brake, to extend at least 2 inches up the vertical wall and at least 3 inches onto the last shingle course; that is, to the top of the cutout.
3. Apply the flashing, 8 inches to 10 inches over the last course of shingles. Embed the flashing in asphalt plastic cement, or another appropriate adhesive, and nail it to the roof every 12 inches. Do not nail the strip to the wall.
4. If side laps are necessary, overlap the pieces at least 6 inches. Do not fasten in this joint area.

Shingle application around flashing

Top and sides:
SHINGLES overlap flange and are set in asphalt plastic cement.

Bottom:
FLANGE overlaps shingles.

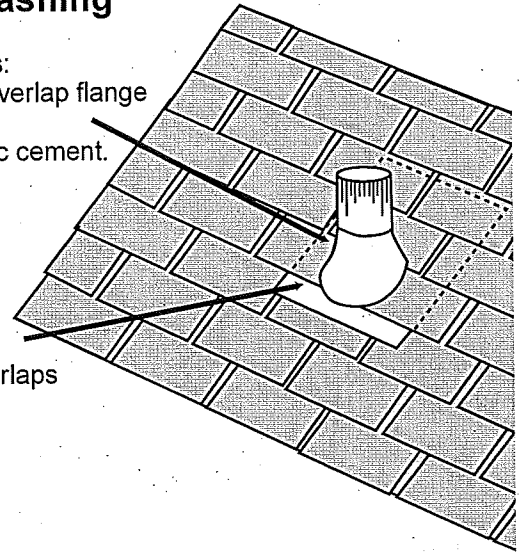

Sidewall flashing (26-Gauge)

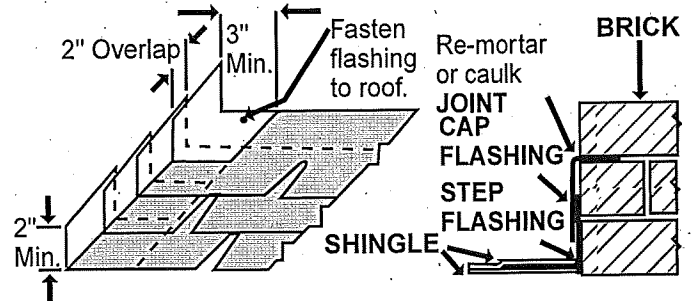

Valley flashing

When existing flashing is no longer serviceable, it shall be replaced. Valley flashing shall consist of not less than No. 26-Gauge corrosion-resistant, galvanized sheet metal or other code approved, valley lining material. The metal shall extend at least 12 inches from the center line each way. Sections of flashing shall have an end lap of not less than four inches. Alternately, the valley may consist of woven asphalt singles or closed-cut style applied in accordance with the manufacturer's instructions.

Other flashing

All other flashing and roof vents shall be checked and if rusted or in bad condition shall be replaced. When replacing flashing of metal, it shall be of not less than No. 26-Gauge corrosion-resistant metal. Roof vents and other flashings must be installed according to manufacturer's instructions. Generally, all require the bottom part of the vent to be placed above the shingles so that about half of the vent is above the lower shingles and half is below the uppermost shingles. Any replacement of flashing at masonry chimneys must be properly cut in and re-tuckpointed or caulked with an approved product.

Ice protection underlayment

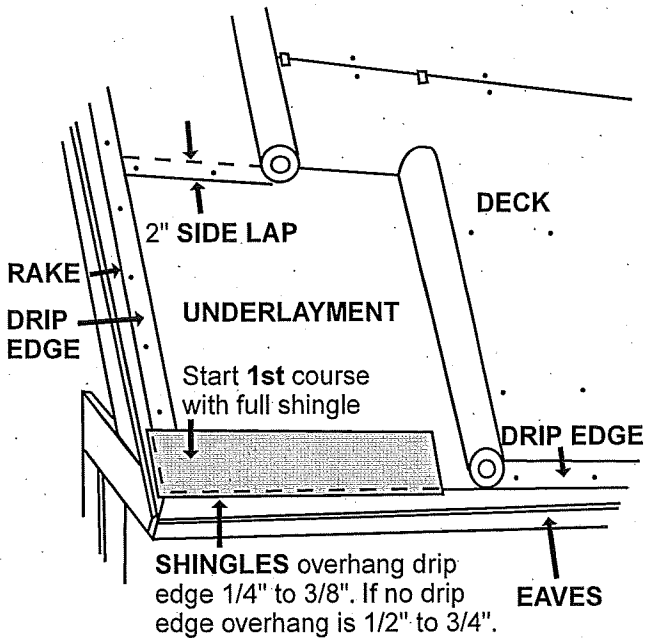

Installation: When applying underlayment, keep the product as wrinkle-free as possible. Unroll the underlayment parallel with the eaves. The underlayment should go over eaves' drip edge flashing, but go under the rake's drip edge flashing.

Kick-out flashing

WATER RESISTIVE BARRIER/HOUSEWRAP
Place over Step Flashing.

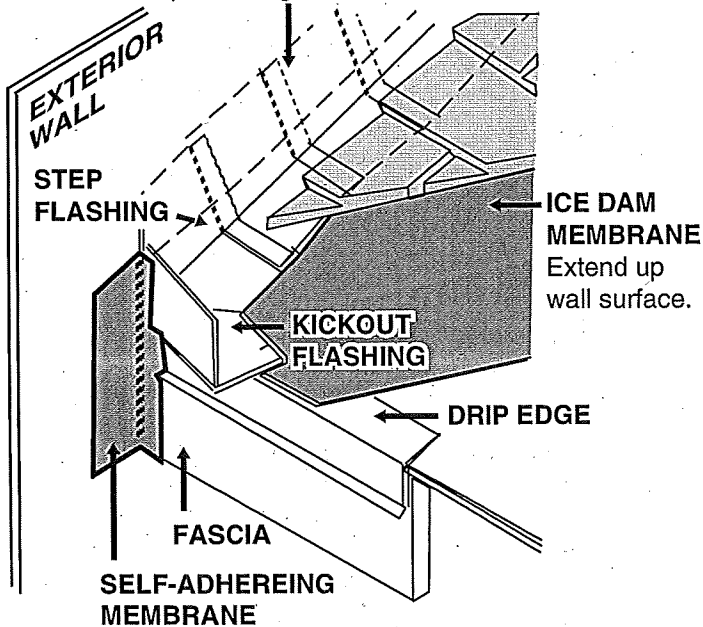

Where to use ice protection

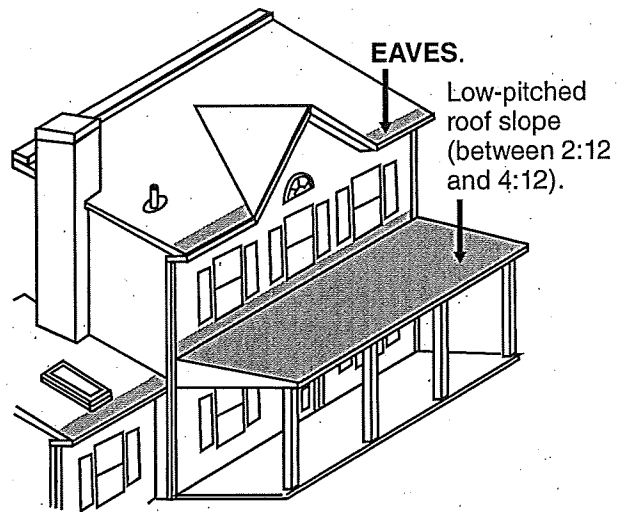

Roof and soffit vents

If necessary, additional roof and soffit vents must be installed so that for every 300 square feet of attic area there is at least 1 square foot of ventilation. At least 50 percent, but not more than 80 percent, shall be in the upper portion of the roof and the balance to be provided by eave or soffit vents.

Exhaust vents

Care should be taken to ensure that kitchen and bathroom exhaust fan pipes are connected to the appropriate dampered exhaust roof vent with no openings into the attic that would allow exhaust air back into the attic space. The exhaust vents shall be installed the same as other attic vents and vent pipe flashings.

When re-roofing around furnace flues, take care to not dislodge the joints of the flue pipe within the attic or within interior chases this pipe might pass through. If in doubt, consult a licensed heating contractor.

Crickets and saddles

R905.2.8.3 Crickets and saddles. A cricket or saddle shall be installed on the ridge side of any chimney or penetration more than 30 inches (762 mm) wide as measured perpendicular to the slope. Cricket or saddle coverings shall be sheet metal or of the same material as the roof covering.

Shingle application using 5-inch method

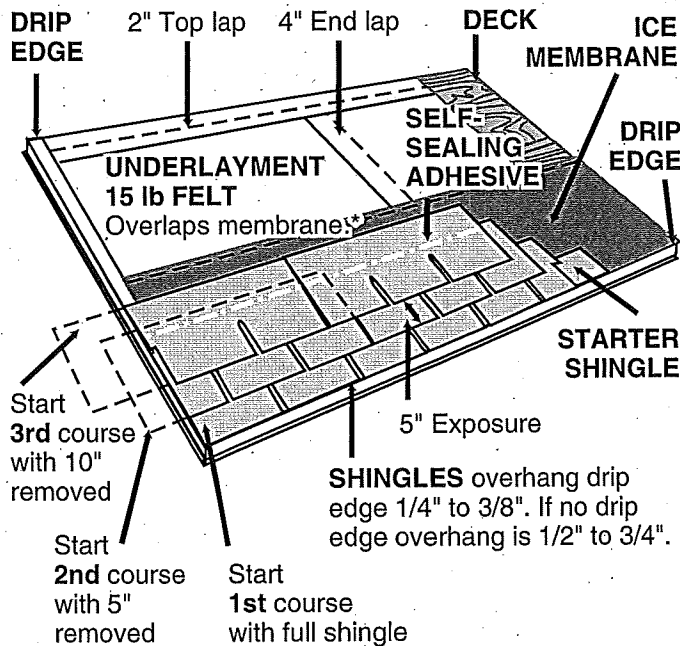

*Felt underlayment must overlap the ice membrane a minimum of 2 inches.

Valley lining material

R905.2.8.2 Valleys. Valley linings shall be installed in accordance with the manufacturer's installation instructions before applying shingles. Valley linings of the following types shall be permitted:

1. For open valley (valley lining exposed) lined with metal, the valley lining shall be at least 24 inches (610 mm) wide and of any of the corrosion-resistant metals in Table R905.2.8.2.
2. For open valleys, valley lining of two plies of mineral surfaced roll roofing, complying with ASTM D 3909 or ASTM D 6380 Class M, shall be permitted. The bottom layer shall be 18 inches (457mm) and the top layer a minimum of 36 inches (914mm) wide.
3. For closed valleys (valley covered with shingles), valley lining of one ply of smooth roll roofing complying with ASTM D 6380 Class S Type III, Class M Type II, or ASTM D 3909 and at least 36 inches wide (914mm) or valley lining as described in Items 1 and 2 above shall be permitted. Specialty underlayment complying with ASTM D 1970 may be used in lieu of the lining material.

Skylight: Basic sheet metal components

All dimensions approximate.

BACKER FLASHING under shingles minimum 3 courses. Where necessary (depending upon anticipated debris and/or snow accumulation), hold shingles up 1 course and nail high.

INTEGRAL COUNTER FLASHING with hemmed drip edge.

COUNTER FLASHING over base and step flashing approx. 2" min.

APRON FLASHING with lower edge hemmed under.

RAISED CURB (2" x 8" suggested as minimum to attain flashing clearance.)

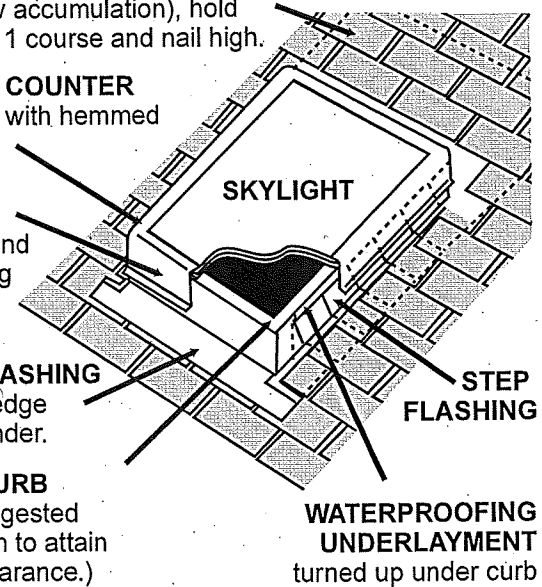

Table R905.2.8.2 – Valley Lining Material

Material	Minimum thickness	Gage	Weight
Cold-rolled copper	0.0216 Nominal	-----	Astm B 370, 16 Oz. per square foot
Lead-coated copper	0.0216 Nominal	-----	Astm B 101, 16 Oz. per square foot
High-Yield Copper	0.0162 Nominal	-----	Astm B 370 12 Oz. per square foot
Lead-coated high-yield copper	0.0162 Nominal	-----	Astm B 101, 12 Oz. per square foot
Aluminum	0.024	-----	-----
Stainless steel	-----	28	-----
Galvanized steel	0.0179	26 (Zinc coated G90)	-----
Zinc Alloy	0.027	-----	-----
Lead	-----	-----	2 1/2
Painted Terne	-----	-----	20

For Si: 1 Inch = 25.4 Mm, 1 Pound = 0.454 Kg.

* Inches.